

**OTC ELECTRICAL  
APPRENTICESHIP PROGRAM**  
P.O. Box 983  
Malvern, AR 72104  
(501) 538-3637

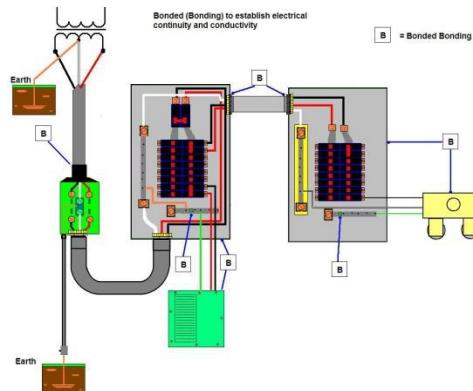

To Whom It May Concern:

I, \_\_\_\_\_, have not performed electrical work in the State of Arkansas since

\_\_\_\_\_  
Signature

\_\_\_\_\_  
Date

Subscribed and sworn to before me this

\_\_\_\_\_ Day of \_\_\_\_\_, 20\_\_

\_\_\_\_\_  
Notary Public